



Ruckus Wireless™ SmartCell Gateway™ 200

Charging Interface Reference Guide for SmartZone 3.4.1

Part Number 800-71373-001 Rev A
Published July 2016

www.ruckuswireless.com

Copyright Notice and Proprietary Information

Copyright 2016. Ruckus Wireless, Inc. All rights reserved.

No part of this documentation may be used, reproduced, transmitted, or translated, in any form or by any means, electronic, mechanical, manual, optical, or otherwise, without prior written permission of Ruckus Wireless, Inc. ("Ruckus"), or as expressly provided by under license from Ruckus.

Destination Control Statement

Technical data contained in this publication may be subject to the export control laws of the United States of America. Disclosure to nationals of other countries contrary to United States law is prohibited. It is the reader's responsibility to determine the applicable regulations and to comply with them.

Disclaimer

THIS DOCUMENTATION AND ALL INFORMATION CONTAINED HEREIN ("MATERIAL") IS PROVIDED FOR GENERAL INFORMATION PURPOSES ONLY. RUCKUS AND ITS LICENSORS MAKE NO WARRANTY OF ANY KIND, EXPRESS OR IMPLIED, WITH REGARD TO THE MATERIAL, INCLUDING, BUT NOT LIMITED TO, THE IMPLIED WARRANTIES OF MERCHANTABILITY, NON-INFRINGEMENT AND FITNESS FOR A PARTICULAR PURPOSE, OR THAT THE MATERIAL IS ERROR-FREE, ACCURATE OR RELIABLE. RUCKUS RESERVES THE RIGHT TO MAKE CHANGES OR UPDATES TO THE MATERIAL AT ANY TIME.

Limitation of Liability

IN NO EVENT SHALL RUCKUS BE LIABLE FOR ANY DIRECT, INDIRECT, INCIDENTAL, SPECIAL OR CONSEQUENTIAL DAMAGES, OR DAMAGES FOR LOSS OF PROFITS, REVENUE, DATA OR USE, INCURRED BY YOU OR ANY THIRD PARTY, WHETHER IN AN ACTION IN CONTRACT OR TORT, ARISING FROM YOUR ACCESS TO, OR USE OF, THE MATERIAL.

Trademarks

Ruckus Wireless, Ruckus, the bark logo, ZoneFlex, FlexMaster, ZoneDirector, SmartMesh, Channelfly, Smartcell, Dynamic PSK, and Simply Better Wireless are trademarks of Ruckus Wireless, Inc. in the United States and other countries. All other product or company names may be trademarks of their respective owners.

Contents

About This Guide

Document Conventions	5
Terminology	6
References	7
Legend	7
Related Documentation	8
Online Training Resources	8
Documentation Feedback	8

1 Charging Gateway Function

Overview	10
CGF Interface Description	10

2 CDR Packet Transfer and Formats

CDR Transport by GTP'	14
Normal CDR Packet Transfer	14
Data Transfer Request Message	16
Data Record Packet IE	16
Data Transfer Response Message	17
Node Alive Request Message	18
Node Alive Response Message	18
Redirection Request Message	18
Redirection Response Message	19
CDR Formats	19
S-CDR Type	20
W-CDR Type	22
W-AN-CDR Type	23

Index

About This Guide

This *SmartCell Gateway™ (SCG) 200 Charging Interface Reference Guide* lists all the interface messages used between the SCG and the Charging Gateway Function (CGF) server over a Ga interface. Gateway Function (CGF) server only when the SCG acts a trunk terminating gateway for managing the Ruckus Wireless SmartCell Gateway.

This guide is written for service operators and system administrators who are responsible for managing, configuring, and troubleshooting Ruckus Wireless devices. Consequently, it assumes a basic working knowledge of local area networks, wireless networking, and wireless devices.

NOTE If release notes are shipped with your product and the information there differs from the information in this guide, follow the instructions in the release notes.

Most user guides and release notes are available in Adobe Acrobat Reader Portable Document Format (PDF) or HTML on the Ruckus Wireless Support Web site at <https://support.ruckuswireless.com/contact-us>.

Document Conventions

Table 1 and Table 2 list the text and notice conventions that are used throughout this guide.

Table 1. Text conventions

Convention	Description	Example
monospace	Represents information as it appears on screen	[Device name] >
monospace bold	Represents information that you enter	[Device name] > set ipaddr 10.0.0.12
default font bold	Keyboard keys, software buttons, and field names	On the Start menu, click All Programs.
<i>italics</i>	Screen or page names	Click Advanced Settings . The <i>Advanced Settings</i> page appears.

Table 2. Notice conventions

Notice Type	Description
NOTE	Information that describes important features or instructions
CAUTION!	Information that alerts you to potential loss of data or potential damage to an application, system, or device
WARNING!	Information that alerts you to potential personal injury

Terminology

Table 3 lists the terms used in this guide.

Table 3. Terms used in this guide

Terms	Description
AAA	Authentication, Authorization, and Accounting
AVP	Ruckus Vendor specific attribute Pair
BMD	Billing Mediation Device is a network component in a telecommunications network that receives, processes, reformats and sends information to other formats between network elements.
CDF	Charging Data Function
CDR	A formatted collection of information on chargeable events used for accounting and billing. For example, call set-up, call duration and amount of data transferred.
CGF	Charging Gateway Function
CTF	Charging Trigger Function
DRT	Data Record Transfer
Ga	Reference point between a CDF and the CGF for CDR transfer
GGSN	Gateway GPRS Support Node
GTP	GPRS Tunneling Protocol
GTP'	GPRS protocol, used for CDR transport. It is derived from GTP with enhancements to improve transport reliability necessary for CDRs
IMSI	International Mobile Subscriber Identity
IP-CAN	IP Connectivity Access Network
P-GW	Packet Data Network Gateway
PCN	Packet switched Core network Node (SGSN, GGSN, S-GW, P-GW)
PDN	Packet Data Network
S-CDR	SGSN Call Detail Record
SGSN	Serving GPRS Support Node
UI	User Interface
UMTS	Universal Mobile Telecommunications Service
WAG	WiFi Access Gateway
W-CDR	WLAN Call Detail Record

References

Table 4 lists the specifications and standards that are referred to in this guide.

Table 4. References used in this guide

No.	Title	Description
1	TS 32.295 Release 8	<ul style="list-style-type: none"> Charging management Charging Data Record (CDR) transfer
2	TS 32.252 Release 8	<ul style="list-style-type: none"> Charging management Wireless Local Area Network (WLAN) charging Description about W-CDR
3	TS 32.251 Release 8	<ul style="list-style-type: none"> Charging management Packet Switched (PS) domain charging. Description about S-CDR
4	TS 32.240 Release 8	<ul style="list-style-type: none"> Charging management Charging architecture and principles
5	TS 32.298 Release 8)	<ul style="list-style-type: none"> Charging management Charging Data Record (CDR) parameter description
6	IETF RFC 768 (1980)	User Datagram Protocol (STD 6)

Legend

Table 5 lists the legend/presence used in this guide.

Table 5. Legend used

Legend / Presence	Description
M	Mandatory
O	Optional
C	Conditional
O _M	Operator Provisionable - Attributes that operators have provisioned to be included for all conditions
O _C	Operator Provisionable Conditional (OC): Attributes that operators have provisioned to be included in the CDR provided certain conditions are met

Related Documentation

For a complete list of documents that accompany this release, refer to the Release Notes.

Online Training Resources

To access a variety of online Ruckus Wireless training modules, including free introductory courses to wireless networking essentials, site surveys, and Ruckus Wireless products, visit the Ruckus Wireless Training Portal at:
<https://training.ruckuswireless.com>

Documentation Feedback

Ruckus Wireless is interested in improving its documentation and welcomes your comments and suggestions. You can email your comments to Ruckus Wireless at:

docs@ruckuswireless.com

When contacting us, please include the following information:

- Document title
- Document part number (on the cover page)
- Page number (if appropriate)

For example:

- SCG-200 Charging Interface Reference Guide for SmartZone 3.4.1
- Part number: 800-71373-001
- Page 88

Charging Gateway Function

1

This chapter consists:

- [Overview](#)
- [CGF Interface Description](#)

Overview

This reference guide describe the interface between the SCG-200 and Charging Gateway Function (CGF) server only when the SCG acts as a *trunk terminating gateway*. This guide lists all of the interface messages that are used between the SCG and CGF server (Ga Interface).

NOTE: This guide does not provide design details of the SCG's CDF functionality for the interface requirements.

NOTE: Refer to [About This Guide](#) for the conventions used in this guide.

CGF Interface Description

The Ga interface over GTP' (prime) from the SCG to CGF server, delivers the CDR generated at the SCG. The SCG plays the CTF role of collecting the chargeable event information for TTG sessions, i.e., session towards GGSN/PGW. The SCG as Charging Data Function (CDF) constructs the CDR's, builds data transfer request messages and sends it over to the Ga interface (CGF server(s) configured at the SCG) as defined in 3GPP TS 32.295. Generated CDR's are sent to CGF server and or can be stored locally, based on configuration in the SCG user interface. By definition, dealing with CDRs only implies that Ga is solely related to offline charging (as seen in [Figure 1](#)).

Figure 1. Offline charging architecture

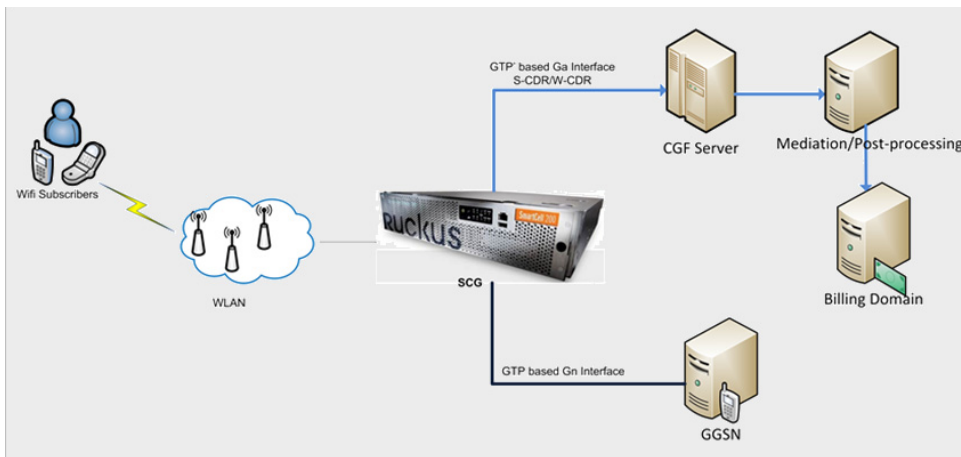

For billing purposes of data services, the SCG together with the hosted AAA server emulates a cellular SGSN. Figure 1 shows the logical deployment of the SCG in a billing domain. The integration enables total reuse of the operator's existing packet billing systems for GPRS/UMTS.

The SCG on the data path measures the user traffic packets (uplink/downlink - per-session). The module in the SCG (TTG control plane) reports these measurements to the SCG hosted AAA server [RAC] using RADIUS accounting messages. The AAA server [RAC] converts the RADIUS accounting records to standard formats of S-CDR (SGSN Call Detail Record) or W-CDR (WLAN Call Detail Record) based on the configuration specified in the user interface.

The SCG can either forward the CDRs directly to CGF(s) and/or store them locally for retrieval by an external system using FTP. On receiving the CDRs from the SCG, the billing domain and BMD determines the layers of charging and charging rules. Charging rules are based on the operator's charging rules, which are logical blocks of offline charging architecture. See Figure 2.

Figure 2. Logical blocks of offline charging architecture

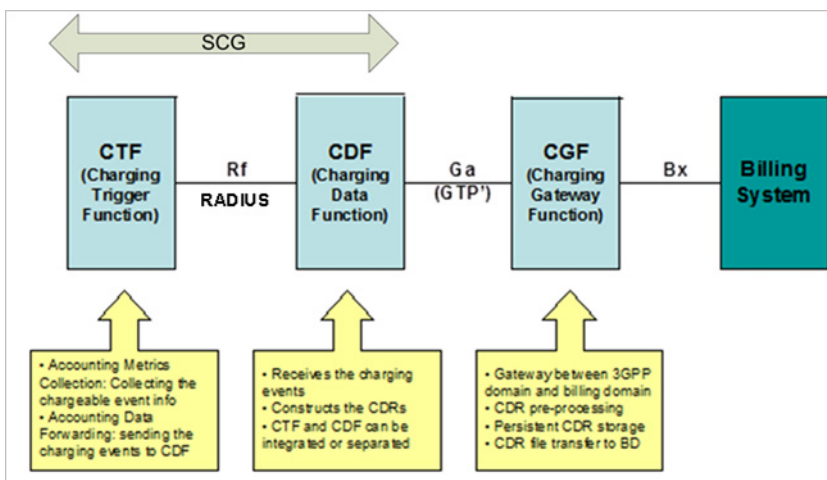

In the data offload solution, SCG plays the CTF (Charging Trigger Function) and CDF (Charging Data Function) in a combined role. As CTF, it collects the chargeable event information including the connecting time and transferred packets and as CDF, it converts the RADIUS accounting information into CDRs. The SCG supports the standard Ga interface based on GTP' for transferring the CDRs to CGF.

The SCG also generates CDR's for accounting messages initiated by AP. For direct IP access session (PDG sessions), the SCG generates W-AN-CDR's for accounting messages initiated from AP, which acts as CDF module.

CDR Packet Transfer and Formats

2

This chapter contains:

- [CDR Transport by GTP'](#)
- [Normal CDR Packet Transfer](#)
- [CDR Formats](#)

CDR Transport by GTP'

The transport protocol associated to the Ga reference point, provides the function for transferring CDRs from the SCG (CDF) to CGF, which is known as GTP' (TS 29.060). See [Figure 3](#).

Standard UDP port 3386 is used for delivering CDR's to the CGF server. GTP message DRT (Data Record Transfer) request is used for delivering data records to the CGF server.

Figure 3. Stack layer between CDF and CGF

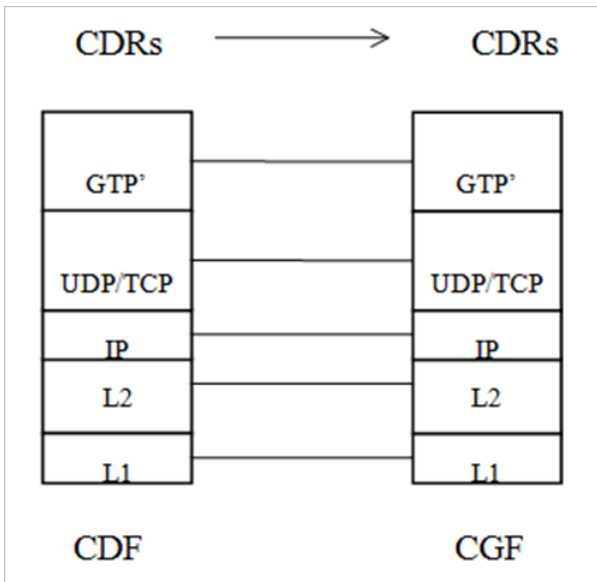

Normal CDR Packet Transfer

CDR generated at the SCG is packed in DRT messages with the packet transfer command having the value - *send data record packet*. Based on the accounting interim message configuration, the SCG sends CDR's as a DRT message to the CGF server for a given user session. If the accounting interim message interval is not configured, the SCG sends the DRT message after the data session ends, which is an *accounting stop message*.

The CDR receiving entity (CGF) sends a confirmation of receiving the packet to the CDF. The confirmation is sent by using the data record transfer response message, with the cause value *request accepted*.

Figure 4 shows the sequence of successful CDR transfers between the SCG and CGF server.

Figure 4. CDR transfer between the SCG and CGF server

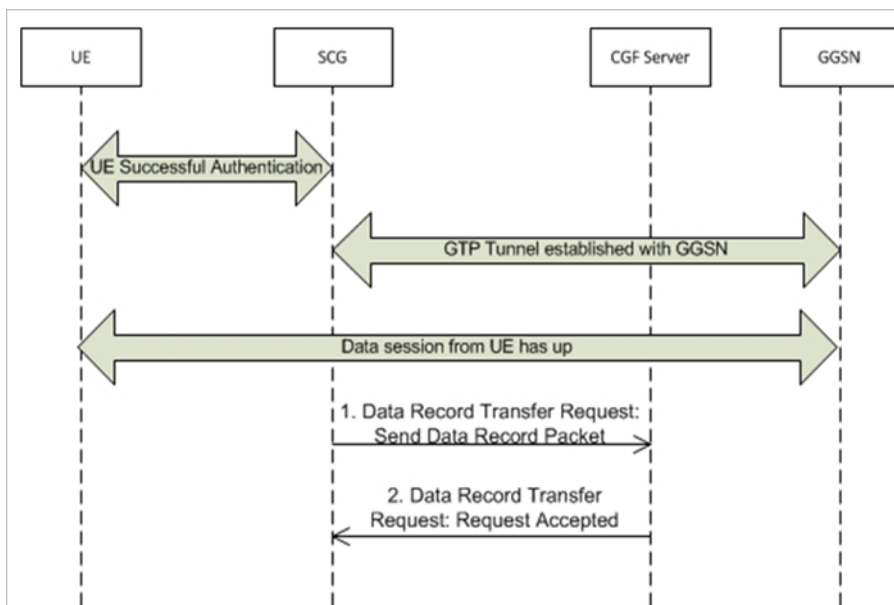

This section covers:

- [Data Transfer Request Message](#)
- [Data Record Packet IE](#)
- [Data Transfer Response Message](#)
- [Node Alive Request Message](#)
- [Node Alive Response Message](#)
- [Redirection Request Message](#)
- [Redirection Response Message](#)

NOTE: Reference for the below messages is [TS 32.295 Release 8](#).

Data Transfer Request Message

This message is sent from the SCG to CGF server. This message is used for transmitting CDR(s) to CGF, where CDRs are placed in the data record packet information element. [Table 6](#) lists the message attributes.

Table 6. Data transfer request attributes

Attribute	Presence	Type	Description
Packet Transfer Command	M	Variable	This attribute is present in the DTR message sent from the SCG. The value is set to 1 in normal DTR message with CD (<i>send data record packet</i>).
Data Record Packet	C	Variable	This attribute is present in the DTR message sent from the SCG. It contains one or more CDR's.
Sequence Numbers of Released Packets	C	NA	Not part of the DTR message sent from the SCG.
Sequence Numbers of Canceled Packets	C	NA	Not part of the DTR message sent from the SCG.
Private Extension	C	NA	Not part of the DTR message sent from the SCG.

Data Record Packet IE

The data record packet IE contains the CDR's generated at the SCG. It can have single or multiple CDR's, based on the user interface configuration specified in the SCG. [Figure 5](#), shows the format of the data record packet.

Figure 5. Data record packet

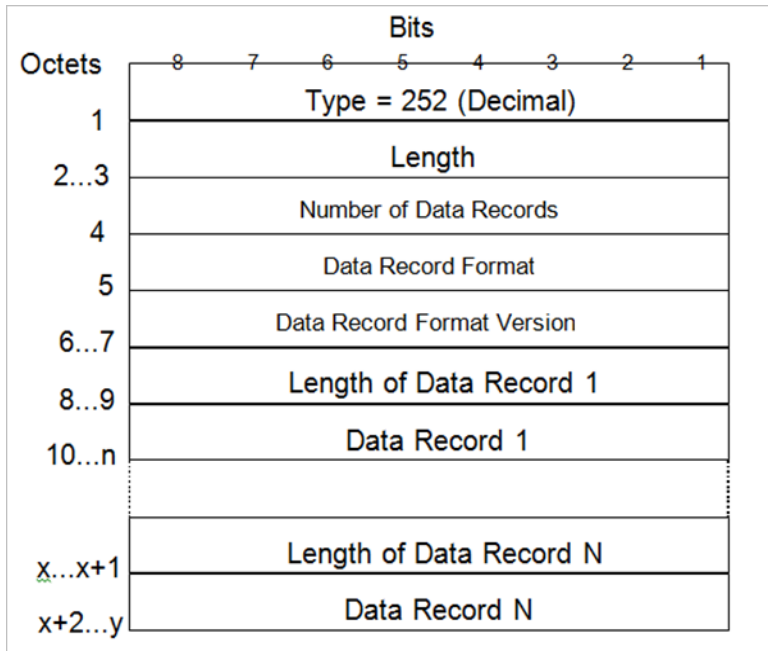

Data Transfer Response Message

This message is sent from CGF server to the SCG as a response for data record transfer request from the SCG. [Table 7](#) lists the message attributes.

Table 7. Data transfer response attributes

Attribute	Presence	Type	Description
Cause	M	Variable	This attribute is present in the response messages sent from the CGF. The value is set to 1 for successful responses.
Request Responded	M	Variable	This attribute is present in the response messages sent from the CGF. The value is set to 5 for successful responses.
Private Extension	C	NA	This attribute is not part of the response message sent from CGF.

Node Alive Request Message

This message is sent from CGF server to the SCG or from the SCG to CGF server during a SCG restart. This request message informs that a node in the network has started its service. For example, a node could start its service due to a break down because of software or hardware maintenance or because of an error. [Table 8](#) lists the message attributes.

Table 8. Node alive request attributes

Attribute	Presence	Type	Description
Node Address	M	IP Address	IP address of the CGF server for CGF initiated messages. IP address of the SCG for SCG initiated messages.
Alternative Node Address	O	IP Address	This attribute is not present in the response message sent from the CGF server.
Private Extension	O	NA	This attribute is not present in the response message sent from the CGF server.

Node Alive Response Message

This message is sent from the SCG to CFG server in response to the received node alive request. [Table 9](#) lists the message attributes.

Table 9. Node alive response attributes

Attribute	Presence	Type	Description
Private Extension	O	NA	This attribute is not present in the response message sent from the SCG to the CGF server.

Redirection Request Message

This message is sent from the CGF server to the SCG. The CGF server sends this message when it is unable to handle the CDR's from the SCG. Reasons could be maintenance or overload at the CGF server or the next node in the chain (such as the mediator device or a billing computer) has lost its connection to the CGF server. [Table 10](#) lists the message attributes.

Table 10. Redirection request attributes

Attribute	Presence	Type	Description
Cause	M	Variable	This attribute results in the SCG stops sending CDR's to the CGF server until it receives the CGF server sends an indication of a node alive request. Value ranges from 1-5.
Address of Recommended Node	O	IP address (IPv4)	IP address of the recommended CGF server. A new DRT is sent to this server.
Alternative Address of the Recommended Node	O	IP address (IPv6)	This is an alternate IP address of the recommended CGF server. The SCG does not consider this address.
Private Extension	O	N/A	This attribute may not be present in the received message.

Redirection Response Message

This message is sent from the SCG to the CGF server as a response for redirection request from the CGF server. [Table 11](#) lists the message attributes.

Table 11. Redirection response attributes

Attribute	Presence	Type	Description
Cause	M	Variable	The SCG sets the cause value to 1 - " <i>Request Accepted</i> ", provided the IP address of the CGF server is configured in the SCG and is seen in the active state.
Private Extension	O	N/A	This attribute may not be present in the received message.

CDR Formats

3GPP specification defines the WLAN-CDR ([TS 32.252 Release 8](#)) and S-CDR ([TS 32.251 Release 8](#)), which mentions the optional fields defined by the operator. To support these, the SCG user interface provides these options for generating the CDRs. The operator can select the CDR type to be generated by configuring the SCG UI. Based on the configuration, the SCG includes or excludes these fields when generating W-CDR/S-CDR. This section defines the following types of formats generated by the SCG:

- [S-CDR Type](#)
- [W-CDR Type](#)
- [W-AN-CDR Type](#)

S-CDR Type

[Table 12](#) lists the attributes of S-CDR type generated by the SCG based on 3GPP specification ([TS 32.251](#)).

Table 12. S-CDR attributes

Attribute	Presence	Description
Record Type	O _M	SGSN IP-CAN bearer identity.
Served IMSI	O _M	IMSI of the served party.
SGSN Address	O _M	IP address of the current SGSN.
Charging ID	O _M	IP-CAN bearer identifier used in identifying the IP CAN bearer present in various records, created by PCNs.
GGSN Address Used	O _M	The control plane IP address of the P-GW currently used. The P-GW address is always the same for an activated IP CAN bearer.
Access Point Name Network Identifier	O _M	The logical name of the connected access point for external packet data network identifier (part of APN).
PDP Type	O _M	PDP type, which could be: <ul style="list-style-type: none"> • IP • PPP • IHOSS • OSP

Table 12. S-CDR attributes (Continued)

Attribute	Presence	Description
Served PDP Address	O _C	PDP address of the served IMSI - IPv4 address or IPv6 prefix. This parameter is present except when the PDP type is PPP and if the dynamic PDP address assignment is used.
List of Traffic Data Volumes	O _M	A list of: <ul style="list-style-type: none"> • Changes in charging conditions for the IP CAN bearer, where each change is time stamped. • Charging conditions is categorized as per traffic volumes. For example, per tariff period - initial and subsequent changes. • QoS and its corresponding data volumes.
Record Opening Time	O _M	Time stamp when IP CAN bearer is activated in the current SGSN or it is the record opening time of subsequent partial records.
Duration	O _M	Duration of the current record in SGSN.
Cause for Record Closing	O _M	The reason for record closures from the current SGSN.
Diagnostics	O _M	Detailed reason for releasing the connection.
Record Sequence Number	C	Partial record sequence number in the current SGSN. It is present only in case of partial records.
Node ID	O _M	Name of the recording entity.
Local Record Sequence Number	O _M	Consecutive record number created by the current node. The number is allocated sequentially, including all CDR types.
APN Selection Mode	O _M	Index indicating the APN selection.
Access Point Name Operator Identifier	O _M	Operator identifier of the APN.
Served MSISDN	O _M	Primary MSISDN of the subscriber.
Charging Characteristics	O _M	Charging characteristics applied to the IP CAN bearer.

W-CDR Type

Table 13 lists the attributes of W-CDR type generated by the SCG based on 3GPP specifications (TS 32.252 Release 8).

Table 13. W-CDR attributes

Attribute	Presence	Description
Record Type	M	WLAN PDG record.
Served IMSI	M	IMSI of the served party.
Served MSISDN	O _M	Primary MSISDN of the subscriber.
PDG Address	M	IP address of the PDG used.
Node ID	O _M	Name of the recording entity, which is configured in the user interface of the SCG.
Serving WAG Address	M	Serving WAG address used in the current record.
WAG PLMN ID	O _M	WAG PLMN identifier (MCC and MNC) used in the current record.
Serving AAA/Server/Proxy Address	M	Serving AAA server /proxy address. It is the SCG IP address, which acts as the AAA server.
Charging ID	M	PDG charging identifier for correlating WLAN
WLAN Session ID	M	WLAN session identifier for correlating WLAN generated information to the PDG.
Access Point Name Network ID	O _M	Logical name of the connected access point to the external packet data network identifier, which is part of APN.
Charging Characteristics	M	This attribute is applied to the PDP context.
Charging Characteristics Selection Mode	O _M	This attribute contains information on selection of charging characteristics.
Record Opening Time	M	Time stamp when end-to-end tunnel is activated in the current PDG or it is the record opening time of subsequent partial records.
Duration	M	Duration of the current record in PDG.
Cause for Record Closing	M	The reason for record closure from the current PDG.
Local Record Sequence Number	O _M	Consecutive record number created by the current node. The number is allocated sequentially and includes all CDR types.
Diagnostics	O _M	Detailed reason for releasing the connection.

W-AN-CDR Type

Table 14 lists the attributes of W-AN-CDR type generated by the SCG for PDG sessions. This is based on 3GPP specifications (TS 32.252 V8.1.0 (2011-09)).

Table 14. W-AN_CDR attributes

Attribute	Presence	Description
Record Type	M	WLAN direct IP access CDR.
Served IMSI	M	IMSI to be retrieved from the username.
Operator Name	M	Hotspot operator name as defined in the SCG (accounting profile name).
Charging ID	M	Accounting Session-ID received from AP for AP initiated messages.
NAS Port	C	Attribute value as received in accounting message from AP.
NAS Port ID	C	Attribute value as received in accounting message from AP.
NAS Port Type	C	Attribute value as received in accounting message from AP.
NAS IP Address	C	Attribute value as received in accounting message from AP.
Data Volume Downlink	C	Attribute value as received in accounting message from AP.
Data Volume Uplink	C	Attribute value as received in accounting message from AP.
Record Opening Time	M	Time stamp as received in accounting message from AP.
Duration	M	Duration of the record.
Cause for Record Closing	M	The reason for record closures.
Node ID	O _M	Name of the recording entity.
Local Record Sequence Number	O _M	Consecutive record number created by the current node. The number is allocated sequentially, including all CDR types.

Index

A

- access point name network identifier 20
- access point name operator identifier 21
- accounting interim message 14
- accounting messages 11
- address of recommended node 19
- alternative address of the recommended node 19
- alternative node address 18
- aPN selection mode 21

B

- billing domain 11

C

- cause 17, 19
- cause for record closing 21, 22
- cDR formats 19
- cDR transport by GTP' 14
- chargeable event 12
- charging characteristics 21
- charging data function 10, 12
- charging gateway function 10
- charging ID 20, 22, 23
- charging trigger function 12

D

- data record packet 16
- data record transfer 14, 17
- data transfer request message 16
- data transfer response message 17
- diagnostics 21
- duration 21, 22

G

- gGSN address used 20

L

- list of traffic data volumes 21
- local record sequence number 21, 23

N

- node address 18
- node alive request message 18
- node alive response message 18
- node ID 21, 22
- normal CDR packet transfer 14

O

- Overview 10

P

- packet transfer command 16
- pDP type 20
- private extension 16, 17, 18, 19

R

- record opening time 21, 22
- record sequence number 21
- record type 20, 23
- redirection request message 18
- redirection response message 19
- request responded 17

S

- s-CDR Type 20
- sequence numbers of canceled packets 16
- sequence numbers of released packets 16
- served IMSI 20, 23
- served MSISDN 21
- served PDP address 20
- sGSN address 20
- sGSN call detail record 11

T

- transport protocol 14
- trunk terminating gateway 10

U

user traffic packets 11

W

w-CDR Type 22

wLAN call detail record 11



Copyright © 2006-2016. Ruckus Wireless, Inc.
350 West Java Dr. Sunnyvale, CA 94089. USA
www.ruckuswireless.com